

RESOLUTION NO. 2025 - 9

A RESOLUTION AUTHORIZING AND DIRECTING THE ADMINISTRATION TO PURCHASE ONE (1) FREIGHTLINER 108SD PLUS THROUGH SOURCEWELL AT A PURCHASE PRICE OF \$273,337.00, AND DECLARING AN EMERGENCY

WHEREAS, the Council authorized membership in the National Joint Power Alliance [now known as Sourcewell], a purchasing cooperative in Ordinance No. 2017-3; and

WHEREAS, the Administration has determined the need for and recommends that this Council authorize the purchase of a Freightliner 108SD Plus for the efficient operation of the Department of Public Service; and

WHEREAS, through Sourcewell, the Administration has identified one (1) Freightliner 108SD Plus at a price of two hundred seventy-three thousand, three hundred and thirty-seven dollars (\$273,337.00) as identified in Exhibit "A" attached hereto; and

WHEREAS, Council may authorize the purchase through the City's membership in the National Joint Power Alliance [now known as Sourcewell], a purchasing cooperative, pursuant to Article V Sections 1 and 6 of the Charter, and Ohio Revised Code Section 9.48 without a competitive bidding process.

NOW, THEREFORE, BE IT RESOLVED by the Council of the City of Parma Heights, County of Cuyahoga, and State of Ohio:

Section 1: That the Administration is hereby authorized and directed to purchase through Sourcewell one (1) Freightliner 108SD Plus for the sum of two hundred seventy-three thousand, three hundred and thirty-seven dollars (\$273,337.00) as identified in Exhibit "A", attached hereto and incorporated by reference.

Section 2: This Council finds and determines that all formal actions of this Council concerning and relating to the adoption of this Resolution were taken in an open meeting of this Council and that all deliberations of the Council and of any of its Committees comprised of a majority of the members of the Council that resulted in those formal actions were in meeting open to the public, in compliance with the law.

Section 3: This Resolution is declared to be an emergency measure necessary for the public peace, health, and safety of the Municipality, and for the further reason it is immediately necessary to authorize this purchase in order to secure the vehicle at the current contract price; wherefore, this Resolution shall be in full force and effect immediately upon its passage by Council and approval by the Mayor.

PASSED: January 27, 2025

Thomas Rounds
PRESIDENT OF COUNCIL

ATTEST: Barbara Allen
CLERK OF COUNCIL

January 27, 2025
APPROVED

FILED WITH
THE MAYOR: January 27, 2025

M. Gallo
MAYOR MARIE GALLO

EXHIBIT A

Prepared for:
ROBERT TOLER
PARMA HEIGHTS CITY OF
6281 PEARL RD
PARMA HEIGHTS, OH 44130
Phone: 440-345-5970

Prepared by:
Greg Simonic
VALLEY FREIGHTLINER, INC.
10901 Brookpark Rd
Parma, OH 44130
Phone: 216-267-4800

A proposal for
PARMA HEIGHTS CITY OF

Prepared by
VALLEY FREIGHTLINER, INC.
Greg Simonic

Jan 20, 2025

Freightliner 108SD Plus

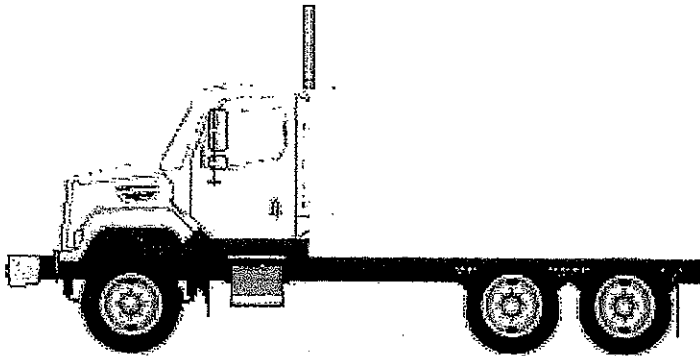

Components shown may not reflect all spec'd options and are not to scale



Prepared for:
 ROBERT TOLER
 PARMA HEIGHTS CITY OF
 6281 PEARL RD
 PARMA HEIGHTS, OH 44130
 Phone: 440-345-5970

Prepared by:
 Greg Simonic
 VALLEY FREIGHTLINER, INC.
 10901 Brookpark Rd
 Parma, OH 44130
 Phone: 216-267-4800

S P E C I F I C A T I O N P R O P O S A L

| Data Code | Description | Weight Front | Weight Rear |
|------------------------------|---|-----------------|----------------|
| Price Level | | | |
| PRL-29D | SD PRL-29D (EFF:MY26 ORDERS) | | |
| Data Version | | | |
| DRL-024 | SPECPRO21 DATA RELEASE VER 024 | | |
| Vehicle Configuration | | | |
| 001-176 | 108SD PLUS CONVENTIONAL CHASSIS | 6,829 | 3,748 |
| 004-226 | 2026 MODEL YEAR SPECIFIED | | |
| 002-004 | SET BACK AXLE - TRUCK | | |
| 019-008 | TOWING PROVISION AT END OF FRAME WITH SAE J560, WITHOUT END OF FRAME AIR CONNECTIONS | 15 | 15 |
| 003-001 | LH PRIMARY STEERING LOCATION | | |
| General Service | | | |
| AA1-002 | TRUCK CONFIGURATION | | |
| AA6-002 | DOMICILED, USA (EXCLUDING CALIFORNIA AND CARB OPT-IN STATES) | | |
| 99D-027 | EPA CLEAN IDLE LABEL FOR INITIAL REGISTRATION IN EPA OR ACT STATES - (INCLUDES 6X4 INCH LABEL ON LOWER FORWARD OF DRIVER DOOR) | | |
| A85-010 | UTILITY/REPAIR/MAINTENANCE SERVICE | | |
| A84-1GM | GOVERNMENT BUSINESS SEGMENT | | |
| AA4-010 | DIRT/SAND/ROCK COMMODITY | | |
| AA5-002 | TERRAIN/DUTY: 100% (ALL) OF THE TIME, IN TRANSIT, IS SPENT ON PAVED ROADS | | |
| AB1-008 | MAXIMUM 8% EXPECTED GRADE | | |
| AB5-001 | SMOOTH CONCRETE OR ASPHALT PAVEMENT - MOST SEVERE IN-TRANSIT (BETWEEN SITES) ROAD SURFACE | | |
| 995-1A0 | FREIGHTLINER SD VOCATIONAL WARRANTY | | |
| A66-99D | EXPECTED FRONT AXLE(S) LOAD : 18000.0 lbs | | |
| A68-99D | EXPECTED REAR DRIVE AXLE(S) LOAD : 46000.0 lbs | | |
| A63-99D | EXPECTED GROSS VEHICLE WEIGHT CAPACITY : 64000.0 lbs | | |
| Truck Service | | | |



Prepared for:
 ROBERT TOLER
 PARMA HEIGHTS CITY OF
 6281 PEARL RD
 PARMA HEIGHTS, OH 44130
 Phone: 440-345-5970

Prepared by:
 Greg Simonic
 VALLEY FREIGHTLINER, INC.
 10901 Brookpark Rd
 Parma, OH 44130
 Phone: 216-267-4800

| | Data Code | Description | Weight Front | Weight Rear |
|------------------------------|-----------|--|-----------------|----------------|
| | AA3-018 | FRONT PLOW/END DUMP BODY | | |
| | AF3-1W0 | HENDERSON | | |
| Engine | | | | |
| | 101-3BU | CUM L9 370 HP @ 2100 RPM; 2100 GOV RPM, 1250 LB-FT @ 1200 RPM | | |
| Electronic Parameters | | | | |
| | 79A-065 | 65 MPH ROAD SPEED LIMIT | | |
| | 79B-000 | CRUISE CONTROL SPEED LIMIT SAME AS ROAD SPEED LIMIT | | |
| | 79G-106 | 10 MINUTE IDLE SHUTDOWN - TIMER RESET WITH CLUTCH AND SERVICE BRAKE | | |
| | 79M-001 | PTO MODE BRAKE OVERRIDE - SERVICE BRAKE APPLIED | | |
| | 79Q-007 | PTO RPM WITH CRUISE RESUME SWITCH - 1100 RPM | | |
| | 79U-007 | PTO GOVERNOR RAMP RATE - 250 RPM PER SECOND | | |
| | 79V-001 | FUEL DOSING OF AFTERTREATMENT ENABLED IN PTO MODE-CLEANS HYDROCARBONS AT HIGH TEMPERATURES ONLY | | |
| | 79W-025 | CRUISE CONTROL BUTTON PTO CONTROL AND ONE REMOTE PTO SPEED | | |
| | 80G-002 | PTO MINIMUM RPM - 700 | | |
| | 80J-001 | REGEN INHIBIT SPEED THRESHOLD - 0 MPH | | |
| | 80S-013 | PTO 1, NO SWITCH, TEM SUPPLIED REQUEST AND INTERLOCK, WITH PTO CONNECTIONS, NO INTERLOCKS | | |
| | 80V-002 | ENGINE MOUNT PTO, DASH SWITCH ENGAGES PTO MODE, DRIVING OPERATION | | |
| Engine Equipment | | | | |
| | 99C-024 | EPA 2010/GHG 2024 CONFIGURATION | | |
| | 13E-001 | STANDARD OIL PAN | | |
| | 105-001 | ENGINE MOUNTED OIL CHECK AND FILL | | |
| | 014-108 | SIDE OF HOOD AIR INTAKE WITH FIREWALL MOUNTED DONALDSON AIR CLEANER WITH SAFETY ELEMENT AND INSIDE/OUTSIDE AIR WITH SNOW DOOR | 10 | |
| | 124-1D9 | DR 12V 180 AMP 28-SI QUADRAMOUNT PAD ALTERNATOR WITH REMOTE BATTERY VOLT SENSE | | |
| | 292-235 | (2) DTNA GENUINE, FLOODED STARTING, MIN 2000CCA, 370RC, THREADED STUD BATTERIES | | |
| | 290-017 | BATTERY BOX FRAME MOUNTED | | |
| | 281-001 | STANDARD BATTERY JUMPERS | | |
| | 282-001 | SINGLE BATTERY BOX FRAME MOUNTED LH SIDE UNDER CAB | | |



Prepared for:
 ROBERT TOLER
 PARMA HEIGHTS CITY OF
 6281 PEARL RD
 PARMA HEIGHTS, OH 44130
 Phone: 440-345-5970

Prepared by:
 Greg Simonic
 VALLEY FREIGHTLINER, INC.
 10901 Brookpark Rd
 Parma, OH 44130
 Phone: 216-267-4800

| Data Code | Description | Weight Front | Weight Rear |
|-----------|---|--------------|-------------|
| 291-017 | WIRE GROUND RETURN FOR BATTERY CABLES WITH ADDITIONAL FRAME GROUND RETURN | | |
| 289-001 | NON-POLISHED BATTERY BOX COVER | | |
| 293-058 | NON-ESSENTIAL POSITIVE LOAD DISCONNECT, IN CAB CONTROL SWITCH MOUNTED OUTBOARD OF DRIVER SEAT | 2 | |
| 295-003 | POSITIVE AND NEGATIVE POSTS FOR JUMPSTART CHASSIS MOUNTED LH BACK OF CAB | 4 | |
| 306-015 | PROGRESSIVE LOW VOLTAGE DISCONNECT AT 12.3 VOLTS FOR DESIGNATED CIRCUITS | 2 | |
| 107-032 | CUMMINS TURBOCHARGED 18.7 CFM AIR COMPRESSOR WITH INTERNAL SAFETY VALVE | | |
| 152-041 | ELECTRONIC ENGINE INTEGRAL SHUTDOWN PROTECTION SYSTEM | | |
| 128-076 | CUMMINS ENGINE INTEGRAL BRAKE WITH VARIABLE GEOMETRY TURBO ON/OFF | 20 | |
| 016-1C2 | RH OUTBOARD UNDER STEP MOUNTED HORIZONTAL AFTERTREATMENT SYSTEM ASSEMBLY WITH RH B-PILLAR MOUNTED VERTICAL TAILPIPE | 30 | 25 |
| 28F-014 | ENGINE AFTERTREATMENT DEVICE, AUTOMATIC OVER THE ROAD REGENERATION AND VIRTUAL REGENERATION REQUEST SWITCH IN CLUSTER | | |
| 239-026 | 10 FOOT 06 INCH (126 INCH+0/-5.9 INCH) EXHAUST SYSTEM HEIGHT | | |
| 233-017 | STANDARD CURVE BRIGHT UPPER STACK(S) | | |
| 237-1CR | RH CURVED VERTICAL TAILPIPE B-PILLAR MOUNTED ROUTED FROM STEP | | |
| 23U-002 | 13 GALLON DIESEL EXHAUST FLUID TANK | | |
| 30N-003 | 100 PERCENT DIESEL EXHAUST FLUID FILL | | |
| 23Y-001 | STANDARD DIESEL EXHAUST FLUID PUMP MOUNTING | | |
| 23Z-002 | NON-POLISHED ALUMINUM DIAMOND PLATE DIESEL EXHAUST FLUID TANK COVER | 15 | 5 |
| 43X-002 | LH MEDIUM DUTY STANDARD DIESEL EXHAUST FLUID TANK LOCATION | | |
| 43Y-001 | STANDARD DIESEL EXHAUST FLUID TANK CAP | | |
| 242-001 | STAINLESS STEEL AFTERTREATMENT DEVICE/MUFFLER/TAILPIPE SHIELD | | |
| 273-058 | AIR POWERED ON/OFF ENGINE FAN CLUTCH | | |
| 276-001 | AUTOMATIC FAN CONTROL WITHOUT DASH SWITCH, NON ENGINE MOUNTED | | |
| 110-003 | CUMMINS SPIN ON FUEL FILTER | | |
| 118-008 | COMBINATION FULL FLOW/BYPASS OIL FILTER | | |
| 266-104 | 1115 SQUARE INCH ALUMINUM RADIATOR | | |
| 103-039 | ANTIFREEZE TO -34F, OAT (NITRITE AND SILICATE FREE) EXTENDED LIFE COOLANT | | |



Prepared for:
 ROBERT TOLER
 PARMA HEIGHTS CITY OF
 6281 PEARL RD
 PARMA HEIGHTS, OH 44130
 Phone: 440-345-5970

Prepared by:
 Greg Simonic
 VALLEY FREIGHTLINER, INC.
 10901 Brookpark Rd
 Parma, OH 44130
 Phone: 216-267-4800

| Data Code | Description | Weight Front | Weight Rear |
|-------------------------------|---|--------------|-------------|
| 171-007 | GATES BLUE STRIPE COOLANT HOSES OR EQUIVALENT | | |
| 172-001 | CONSTANT TENSION HOSE CLAMPS FOR COOLANT HOSES | | |
| 270-016 | RADIATOR DRAIN VALVE | | |
| 360-013 | 1350 ADAPTER FLANGE FOR FRONT PTO PROVISION | 20 | |
| 138-011 | PHILLIPS-TEMRO 1000 WATT/115 VOLT BLOCK HEATER | 4 | |
| 140-022 | CHROME ENGINE HEATER RECEPTACLE MOUNTED UNDER LH DOOR | | |
| 132-004 | ELECTRIC GRID AIR INTAKE WARMER | | |
| 155-058 | DELCO 12V 38MT HD STARTER WITH INTEGRATED MAGNETIC SWITCH | | |
| Transmission | | | |
| 342-582 | ALLISON 3000 RDS AUTOMATIC TRANSMISSION WITH PTO PROVISION | | |
| Transmission Equipment | | | |
| 343-339 | ALLISON VOCATIONAL PACKAGE 223 - AVAILABLE ON 3000/4000 PRODUCT FAMILIES WITH VOCATIONAL MODELS RDS, HS, MH AND TRV | | |
| 84B-012 | ALLISON VOCATIONAL RATING FOR ON/OFF HIGHWAY APPLICATIONS AVAILABLE WITH ALL PRODUCT FAMILIES | | |
| 84C-023 | PRIMARY MODE GEARS, LOWEST GEAR 1, START GEAR 1, HIGHEST GEAR 6, AVAILABLE FOR 3000/4000 PRODUCT FAMILIES ONLY | | |
| 84D-023 | SECONDARY MODE GEARS, LOWEST GEAR 1, START GEAR 1, HIGHEST GEAR 6, AVAILABLE FOR 3000/4000 PRODUCT FAMILIES ONLY | | |
| 84E-013 | S1 PERFORMANCE PRIMARY SHIFT SCHEDULE, AVAILABLE FOR 3000/4000 PRODUCT FAMILIES ONLY | | |
| 84F-016 | S5 PERFORMANCE LIMITING SECONDARY SHIFT SCHEDULE, AVAILABLE FOR 3000/4000 PRODUCT FAMILIES ONLY | | |
| 84G-013 | 2100 RPM PRIMARY MODE SHIFT SPEED | | |
| 84H-013 | 2100 RPM SECONDARY MODE SHIFT SPEED | | |
| 84K-002 | 2ND GEAR ENGINE BRAKE ALTERNATE PRESELECT WITH MODERATE DOWNSHIFT STRATEGY | | |
| 84N-011 | NEUTRAL AT STOP ENABLED | | |
| 84U-000 | DRIVER SWITCH INPUT - DEFAULT - NO SWITCHES | | |
| 84V-001 | DIRECTION CHANGE ENABLED WITH MULTIPLEXED SERVICE BRAKES - ALLISON 5TH GEN TRANSMISSIONS | | |



Prepared for:
 ROBERT TOLER
 PARMA HEIGHTS CITY OF
 6281 PEARL RD
 PARMA HEIGHTS, OH 44130
 Phone: 440-345-5970

Prepared by:
 Greg Simonic
 VALLEY FREIGHTLINER, INC.
 10901 Brookpark Rd
 Parma, OH 44130
 Phone: 216-267-4800

| Data Code | Description | Weight Front | Weight Rear |
|-----------|--|--------------|-------------|
| 353-074 | QUICKFIT BODY LIGHTING CONNECTOR UNDER CAB, WITH BLUNTCUTS | | |
| 34C-011 | ELECTRONIC TRANSMISSION WIRING TO CUSTOMER INTERFACE CONNECTOR | | |
| 362-2JT | CUSTOMER INSTALLED CHELSEA 281 SERIES PTO | | |
| 363-001 | PTO MOUNTING, LH SIDE OF MAIN TRANSMISSION ALLISON | | |
| 341-018 | MAGNETIC PLUGS, ENGINE DRAIN, TRANSMISSION DRAIN, AXLE(S) FILL AND DRAIN | | |
| 345-003 | PUSH BUTTON ELECTRONIC SHIFT CONTROL, DASH MOUNTED | | |
| 97G-004 | TRANSMISSION PROGNOSTICS - ENABLED 2013 | | |
| 370-015 | WATER TO OIL TRANSMISSION COOLER, IN RADIATOR END TANK | 15 | |
| 346-003 | TRANSMISSION OIL CHECK AND FILL WITH ELECTRONIC OIL LEVEL CHECK | | |
| 35T-001 | SYNTHETIC TRANSMISSION FLUID (TES-295 COMPLIANT) | | |

Front Axle and Equipment

| | | | |
|---------|---|-----|--|
| 400-1BA | DETROIT DA-F-18.0-5 18,000# FL1 71.0 KPI/3.74 DROP SINGLE FRONT AXLE | 210 | |
| 402-030 | MERITOR 16.5X6 Q+ CAST SPIDER CAM FRONT BRAKES, DOUBLE ANCHOR, FABRICATED SHOES | 10 | |
| 403-002 | NON-ASBESTOS FRONT BRAKE LINING | | |
| 419-023 | CONMET CAST IRON FRONT BRAKE DRUMS | | |
| 427-001 | FRONT BRAKE DUST SHIELDS | 5 | |
| 409-006 | FRONT OIL SEALS | | |
| 408-001 | VENTED FRONT HUB CAPS WITH WINDOW, CENTER AND SIDE PLUGS - OIL | | |
| 416-022 | STANDARD SPINDLE NUTS FOR ALL AXLES | | |
| 405-031 | HALDEX AUTOMATIC FRONT SLACK ADJUSTERS WITH STAINLESS STEEL CLEVIS PINS | | |
| 406-001 | STANDARD KING PIN BUSHINGS | | |
| 536-012 | TRW TAS-85 POWER STEERING | 40 | |
| 539-003 | POWER STEERING PUMP | | |
| 534-003 | 4 QUART POWER STEERING RESERVOIR | 5 | |
| 533-001 | OIL/AIR POWER STEERING COOLER | 5 | |
| 40T-003 | SYNTHETIC 40/50W FRONT AXLE LUBE | | |

Front Suspension

| | | | |
|---------|--|-----|--|
| 620-006 | 20,000# FLAT LEAF FRONT SUSPENSION | 310 | |
| 619-004 | GRAPHITE BRONZE BUSHINGS WITH SEALS - FRONT SUSPENSION | | |



Prepared for:
 ROBERT TOLER
 PARMA HEIGHTS CITY OF
 6281 PEARL RD
 PARMA HEIGHTS, OH 44130
 Phone: 440-345-5970

Prepared by:
 Greg Simonic
 VALLEY FREIGHTLINER, INC.
 10901 Brookpark Rd
 Parma, OH 44130
 Phone: 216-267-4800

| Data Code | Description | Weight Front | Weight Rear |
|--------------------------------|--|--------------|-------------|
| 410-001 | FRONT SHOCK ABSORBERS | | |
| Rear Axle and Equipment | | | |
| 420-103 | MERITOR RT-46-160 46,000# R-SERIES TANDEM REAR AXLE | | 2,960 |
| 421-614 | 6.14 REAR AXLE RATIO | | |
| 424-001 | IRON REAR AXLE CARRIER WITH STANDARD AXLE HOUSING | | |
| 386-046 | SPL140HD DANA SPICER MAIN DRIVELINE WITH HALF ROUND YOKES | 25 | 25 |
| 388-012 | SPL170 XL DANA SPICER INTERAXLE DRIVELINE WITH HALF ROUND YOKES | | 10 |
| 452-006 | DRIVER CONTROLLED TRACTION DIFFERENTIAL - BOTH TANDEM REAR AXLES | | 30 |
| 878-022 | (1) INTERAXLE LOCK VALVE, (1) DRIVER CONTROLLED DIFFERENTIAL LOCK FORWARD-REAR AXLE VALVE AND (1) REAR-REAR AXLE VALVE | | |
| 87A-005 | INDICATOR LIGHT FOR EACH INTERAXLE LOCKOUT SWITCH | | |
| 87B-014 | INDICATOR LIGHT AND BUZZER FOR EACH DIFFERENTIAL LOCKOUT SWITCH, ENGAGE <5 MPH, DISENGAGE >25 MPH | | |
| 423-033 | MERITOR 16.5X7 Q+ CAST SPIDER HEAVY DUTY CAM REAR BRAKES, DOUBLE ANCHOR, FABRICATED SHOES | | |
| 433-002 | NON-ASBESTOS REAR BRAKE LINING | | |
| 434-019 | ASPHALT SPREADER CLEARANCE REAR BRAKE GEOMETRY | | |
| 451-023 | CONMET CAST IRON REAR BRAKE DRUMS | | |
| 425-002 | REAR BRAKE DUST SHIELDS | | 10 |
| 440-006 | REAR OIL SEALS | | |
| 426-1B3 | BENDIX EVERSURE LONGSTROKE 2-DRIVE AXLES SPRING PARKING CHAMBERS | | 20 |
| 428-031 | HALDEX AUTOMATIC REAR SLACK ADJUSTERS WITH STAINLESS STEEL CLEVIS PINS | | |
| 41T-002 | CURRENT AVAILABLE SYNTHETIC 75W-90 REAR AXLE LUBE | | |
| 42T-001 | STANDARD REAR AXLE BREATHER(S) | | |
| Rear Suspension | | | |
| 622-312 | HENDRICKSON HAULMAAX EX 46,000# REAR SUSPENSION | | 50 |
| 621-1AP | HENDRICKSON HAULMAAX/ULTIMAAX - 10.50" RIDE HEIGHT | | |
| 624-011 | 52 INCH AXLE SPACING | | |
| 628-010 | HENDRICKSON HN, HAULMAAX AND ULTIMAAX SERIES STEEL BEAMS WITH BAR PIN | | |



Prepared for:
 ROBERT TOLER
 PARMA HEIGHTS CITY OF
 6281 PEARL RD
 PARMA HEIGHTS, OH 44130
 Phone: 440-345-5970

Prepared by:
 Greg Simonic
 VALLEY FREIGHTLINER, INC.
 10901 Brookpark Rd
 Parma, OH 44130
 Phone: 216-267-4800

| Data Code | Description | Weight Front | Weight Rear |
|-------------------------------|--|--------------|-------------|
| 623-016 | STANDARD DUTY FORE/AFT AND HEAVY DUTY TRANSVERSE CONTROL RODS | | |
| 625-008 | DOUBLE REBOUND STRAP - INBOARD AND OUTBOARD | | 13 |
| Pusher / Tag Equipment | | | |
| 429-998 | NO PUSHER/TAG BRAKE DUST SHIELDS | | |
| Brake System | | | |
| 490-1AU | WABCO 4S/4M ABS WITH TRACTION CONTROL WITH ATC SHUT OFF SWITCH | | |
| 871-001 | REINFORCED NYLON, FABRIC BRAID AND WIRE BRAID CHASSIS AIR LINES | | |
| 904-001 | FIBER BRAID PARKING BRAKE HOSE | | |
| 412-001 | STANDARD BRAKE SYSTEM VALVES | | |
| 46D-002 | STANDARD AIR SYSTEM PRESSURE PROTECTION SYSTEM | | |
| 413-002 | STD U.S. FRONT BRAKE VALVE | | |
| 432-003 | RELAY VALVE WITH 5-8 PSI CRACK PRESSURE, NO REAR PROPORTIONING VALVE | | |
| 480-009 | BW AD-9 BRAKE LINE AIR DRYER WITH HEATER | 20 | |
| 479-004 | AIR DRYER MOUNTED OUTBOARD ON LH RAIL AT BACK OF CAB | | |
| 460-007 | ALUMINUM AIR BRAKE RESERVOIRS | -10 | -15 |
| 477-016 | BW DV-2 AUTO DRAIN VALVE WITHOUT HEATER TO WET TANK; DRAIN VALVE CABLES ON ALL OTHER TANKS | | |
| Trailer Connections | | | |
| 481-998 | NO TRAILER AIR HOSE | | |
| 476-998 | NO AIR HOSE HANGER | | |
| 296-027 | PRIMARY CONNECTOR/RECEPTACLE WIRED FOR COMBINATION STOP/TURN, CENTER PIN POWERED THROUGH IGNITION WITH STOP SIGNAL PREWIRE PACKAGE | | |
| 303-026 | SAE J560 7-WAY PRIMARY TRAILER CABLE RECEPTACLE TEMPORARY TIED & COILED IN CHASSIS END OF FRAME WITH 2' ADDITIONAL; NO BRACKETS | | |
| 310-998 | NO TRAILER ELECTRICAL CABLE | | |
| Wheelbase & Frame | | | |
| 545-457 | 4575MM (180 INCH) WHEELBASE | | |
| 546-102 | 7/16X3-9/16X11-1/8 INCH STEEL FRAME (11.11MMX282.6MM/0.437X11.13 INCH) 120KSI | 240 | 130 |
| 547-001 | 1/4 INCH (6.35MM) C-CHANNEL INNER FRAME REINFORCEMENT | 170 | 360 |
| 548-803 | TEM TO EVALUATE AND INSTALL FRAME RAIL REINFORCEMENT AS NEEDED FOR FRONT FRAME MOUNTED EQUIPMENT | | |



Prepared for:
 ROBERT TOLER
 PARMA HEIGHTS CITY OF
 6281 PEARL RD
 PARMA HEIGHTS, OH 44130
 Phone: 440-345-5970

Prepared by:
 Greg Simonic
 VALLEY FREIGHTLINER, INC.
 10901 Brookpark Rd
 Parma, OH 44130
 Phone: 216-267-4800

| Data Code | Description | Weight Front | Weight Rear |
|--------------------------|--|--------------|-------------|
| 552-007 | 2450MM (96 INCH) REAR FRAME OVERHANG | | |
| 55W-009 | FRAME OVERHANG RANGE: 91 INCH TO 100 INCH | -70 | 300 |
| 549-002 | 24 INCH INTEGRAL FRONT FRAME EXTENSION | 140 | -20 |
| AC8-99D | CALC'D BACK OF CAB TO REAR SUSP C/L (CA) : 114.57 in | | |
| AE8-99D | CALCULATED EFFECTIVE BACK OF CAB TO REAR SUSPENSION C/L (CA) : 111.57 in | | |
| AE4-99D | CALC'D FRAME LENGTH - OVERALL : 341.78 in | | |
| FSS-0LH | CALCULATED FRAME SPACE LH SIDE : 34.81 in | | |
| FSS-0RH | CALCULATED FRAME SPACE RH SIDE : 60.45 in | | |
| AM6-99D | CALC'D SPACE AVAILABLE FOR DECKPLATE : 0.0 in | | |
| 553-001 | SQUARE END OF FRAME | | |
| 550-001 | FRONT CLOSING CROSSMEMBER | | |
| 559-003 | LIGHTWEIGHT HEAVY DUTY ALUMINUM ENGINE CROSSMEMBER | -12 | |
| 562-001 | STANDARD MIDSHIP #1 CROSSMEMBER(S) | | |
| 572-001 | STANDARD REARMOST CROSSMEMBER | | |
| 565-001 | STANDARD SUSPENSION CROSSMEMBER | | |
| Chassis Equipment | | | |
| 556-997 | OMIT FRONT BUMPER, CUSTOMER INSTALLED SPECIAL BUMPER, DOES NOT COMPLY WITH FMCSR 393.203 | -110 | |
| 585-042 | BETTS B-25 PAINTED MUDFLAP BRACKETS | | 15 |
| 590-001 | BLACK MUDFLAPS | | 15 |
| 551-007 | GRADE 8 THREADED HEX HEADED FRAME FASTENERS | | |
| 44Z-005 | EXTERIOR HARNESSES WRAPPED IN ABRASION TAPE, SECONDARY COVERING, & CONNECTOR PROTECTION | | |
| 605-017 | LEVEL FRAME RAILS (+1%, -0%) WHEN CHASSIS IS LOADED TO FRONT AND REAR SUSPENSION RATINGS | | |
| Fifth Wheel | | | |
| 578-998 | NO FIFTH WHEEL | | |
| Fuel Tanks | | | |
| 204-151 | 60 GALLON/227 LITER ALUMINUM FUEL TANK - LH | | |
| 218-006 | 25 INCH DIAMETER FUEL TANK(S) | | |
| 215-007 | PLAIN ALUMINUM/PAINTED STEEL FUEL/HYDRAULIC TANK(S) WITH POLISHED STAINLESS STEEL BANDS | | |
| 212-007 | FUEL TANK(S) FORWARD | | |
| 664-001 | PLAIN STEP FINISH | | |



Prepared for:
 ROBERT TOLER
 PARMA HEIGHTS CITY OF
 6281 PEARL RD
 PARMA HEIGHTS, OH 44130
 Phone: 440-345-5970

Prepared by:
 Greg Simonic
 VALLEY FREIGHTLINER, INC.
 10901 Brookpark Rd
 Parma, OH 44130
 Phone: 216-267-4800

| Data Code | Description | Weight Front | Weight Rear |
|---------------------|---|--------------|-------------|
| 205-002 | CHROME FUEL TANK CAP(S) | | |
| 122-1H8 | DAVCO 245 FUEL/WATER SEPARATOR WITH 12 VOLT HEAT AND WATER IN FUEL SENSOR | 5 | |
| 216-020 | EQUIFLO INBOARD FUEL SYSTEM | | |
| 202-016 | HIGH TEMPERATURE REINFORCED NYLON FUEL LINE | | |
| Tires | | | |
| 093-2CC | MICHELIN XZU-S2 315/80R22.5 20 PLY RADIAL FRONT TIRES | 100 | |
| * 094-2EC | BRIDGESTONE M799 12R22.5 16 PLY RADIAL REAR TIRES | | 280 |
| Hubs | | | |
| 418-060 | CONMET PRESET PLUS PREMIUM IRON FRONT HUBS | | |
| 450-060 | CONMET PRESET PLUS PREMIUM IRON REAR HUBS | | |
| Wheels | | | |
| 502-433 | ACCURIDE 29039 22.5X9.00 10-HUB PILOT 5.25 INSET 5-HAND STEEL DISC FRONT WHEELS | 66 | |
| 505-428 | ACCURIDE 28828 22.5X8.25 10-HUB PILOT 2-HAND HD STEEL DISC REAR WHEELS | | 104 |
| 496-011 | FRONT WHEEL MOUNTING NUTS | | |
| 497-011 | REAR WHEEL MOUNTING NUTS | | |
| Cab Exterior | | | |
| 829-1A5 | 108 INCH BBC FLAT ROOF ALUMINUM CONVENTIONAL CAB | | |
| 650-008 | AIR CAB MOUNTING | | |
| 705-012 | CAB ROOF REINFORCEMENTS FOR ROOF MOUNTED COMPONENTS | 2 | |
| 648-002 | NONREMOVABLE BUGSCREEN MOUNTED BEHIND GRILLE | | |
| 667-037 | SHORT FENDER WITH MUDFLAP | | |
| 754-017 | BOLT-ON MOLDED FLEXIBLE FENDER EXTENSIONS | 10 | |
| 678-067 | SAFETY YELLOW LH AND RH INTERIOR GRAB HANDLES AND LH AND RH EXTERIOR GRAB HANDLES WITH SINGLE RUBBER INSERT | | |
| 645-002 | BRIGHT FINISH RADIATOR SHELL/HOOD BEZEL | | |
| 646-042 | STATIONARY BLACK GRILLE WITH BRIGHT ACCENTS | | |
| 65X-003 | CHROME HOOD MOUNTED AIR INTAKE GRILLE | | |
| 644-004 | FIBERGLASS HOOD | | |
| 690-007 | HOOD LINER INSULATION WITH SINGLE FIREWALL INSULATION | | |
| 727-1AF | SINGLE 14 INCH ROUND HADLEY AIR HORN UNDER LH DECK | | |



Prepared for:
 ROBERT TOLER
 PARMA HEIGHTS CITY OF
 6281 PEARL RD
 PARMA HEIGHTS, OH 44130
 Phone: 440-345-5970

Prepared by:
 Greg Simonic
 VALLEY FREIGHTLINER, INC.
 10901 Brookpark Rd
 Parma, OH 44130
 Phone: 216-267-4800

| Data Code | Description | Weight Front | Weight Rear |
|---------------------|---|--------------|-------------|
| 726-001 | SINGLE ELECTRIC HORN | | |
| 575-001 | REAR LICENSE PLATE MOUNT END OF FRAME | | |
| 312-067 | HALOGEN COMPOSITE HEADLAMPS WITH BRIGHT BEZELS | | |
| 302-047 | LED AERODYNAMIC MARKER LIGHTS | | |
| 314-823 | WIRING AND SWITCH FOR CUSTOMER FURNISHED SNOW PLOW LAMPS WITH SINGLE CONNECTION AT LH FORWARD | | |
| 311-998 | NO DAYTIME RUNNING LIGHTS | | |
| 294-1AY | INTEGRAL LED STOP/TAIL/BACKUP LIGHTS | | |
| 300-015 | STANDARD FRONT TURN SIGNAL LAMPS | | |
| 744-1BC | DUAL WEST COAST BRIGHT FINISH HEATED MIRRORS WITH LH AND RH REMOTE | | |
| 797-001 | DOOR MOUNTED MIRRORS | | |
| 796-001 | 102 INCH EQUIPMENT WIDTH | | |
| 743-204 | LH AND RH 8 INCH BRIGHT FINISH CONVEX MIRRORS MOUNTED UNDER PRIMARY MIRRORS | | |
| 74A-001 | RH DOWN VIEW MIRROR | | |
| 729-001 | STANDARD SIDE/REAR REFLECTORS | | |
| 677-055 | RH AFTERTREATMENT SYSTEM CAB ACCESS WITH POLISHED DIAMOND PLATE COVER | | |
| 275-061 | PARK BRAKE REMINDER WARNING SYSTEM | | |
| 768-043 | 63X14 INCH TINTED REAR WINDOW | | |
| 661-004 | TINTED DOOR GLASS LH AND RH WITH TINTED OPERATING WING WINDOWS | | |
| 654-011 | RH AND LH ELECTRIC POWERED WINDOWS | | |
| 663-029 | 1-PIECE BONDED HEATED WIPER PARK SOLAR GREEN GLASS WINDSHIELD | | |
| 659-007 | 8 LITER (2 GAL) WINDSHIELD WASHER RESERVOIR, CAB MOUNTED, WITHOUT FLUID LEVEL INDICATOR | | |
| Cab Interior | | | |
| 055-019 | RUGGED TRIM PACKAGE | | |
| 707-107 | GRAY & CARBON VINYL INTERIOR "RUGGED" | | |
| 70K-020 | CARBON WITH PREMIUM GUNMETAL ACCENT (RUGGED) | | |
| 706-013 | MOLDED PLASTIC DOOR PANEL | | |
| 708-013 | MOLDED PLASTIC DOOR PANEL | | |
| 772-006 | BLACK MATS WITH SINGLE INSULATION | | |
| 785-035 | ASH CUP AND (1)LIGHTER,(1)DASH MOUNTED DUAL USB-C OUTLET | | |
| 691-001 | FORWARD ROOF MOUNTED CONSOLE | | |
| 693-019 | LH AND RH DOOR STORAGE POCKETS INTEGRATED INTO MOLDED DOOR PANELS | | |
| 738-021 | DIGITAL ALARM CLOCK IN DRIVER DISPLAY | | |



Prepared for:
 ROBERT TOLER
 PARMA HEIGHTS CITY OF
 6281 PEARL RD
 PARMA HEIGHTS, OH 44130
 Phone: 440-345-5970

Prepared by:
 Greg Simonic
 VALLEY FREIGHTLINER, INC.
 10901 Brookpark Rd
 Parma, OH 44130
 Phone: 216-267-4800

| Data Code | Description | Weight Front | Weight Rear |
|-----------|---|--------------|-------------|
| 742-007 | (2) CUP HOLDERS LH AND RH DASH | | |
| 680-029 | M2/SD DASH | | |
| 720-002 | 2-1/2 LB. FIRE EXTINGUISHER | 5 | |
| 700-002 | HEATER, DEFROSTER AND AIR CONDITIONER | | |
| 701-008 | STANDARD HVAC DUCTING WITH SNOW SHIELD FOR FRESH AIR INTAKE | | |
| 703-005 | MAIN HVAC CONTROLS WITH RECIRCULATION SWITCH | | |
| 170-015 | STANDARD HEATER PLUMBING | | |
| 130-041 | VALEO HEAVY DUTY A/C REFRIGERANT COMPRESSOR | | |
| 702-002 | BINARY CONTROL, R-134A | | |
| 739-034 | PREMIUM INSULATION | | |
| 285-013 | SOLID-STATE CIRCUIT PROTECTION AND FUSES | | |
| 280-007 | 12V NEGATIVE GROUND ELECTRICAL SYSTEM | | |
| 324-1B2 | PREMIUM LED CAB LIGHTING | | |
| 787-998 | NO SECURITY DEVICE | | |
| 657-001 | DOOR LOCKS AND IGNITION SWITCH KEYED THE SAME | | |
| 78G-004 | KEY QUANTITY OF 4 | | |
| 655-028 | LH AND RH ELECTRIC DOOR LOCKS WITH AUTO UNLOCK FEATURE WHEN DOOR IS SET FROM OPEN TO CLOSED POSITION | | |
| 740-998 | NO MATTRESS | -20 | -15 |
| 722-002 | TRIANGULAR REFLECTORS WITHOUT FLARES | 10 | |
| 756-339 | PREMIUM ISRINGHAUSEN HIGH BACK AIR SUSPENSION DRIVERS SEAT WITH 2 AIR LUMBAR, INTEGRATED CUSHION EXTENSION, TILT AND ADJUSTABLE SHOCK | 70 | |
| 760-336 | BASIC ISRI HIGH BACK NON SUSPENSION PASSENGER SEAT WITH FORE AND AFT ADJUSTMENT | | |
| 759-007 | DUAL DRIVER SEAT ARMRESTS, NO PASSENGER SEAT ARMRESTS | 4 | |
| 711-004 | LH AND RH INTEGRAL DOOR PANEL ARMRESTS | | |
| 758-1AK | BLACK VINYL DRIVER SEAT COVER | | |
| 761-014 | BLACK CORDURA PLUS CLOTH PASSENGER SEAT COVER | | |
| 763-101 | BLACK SEAT BELTS | | |
| 532-002 | ADJUSTABLE TILT AND TELESCOPING STEERING COLUMN | | |
| 540-044 | 4-SPOKE 18 INCH (450MM) BLACK STEERING WHEEL WITH SWITCHES | | |
| 765-002 | DRIVER AND PASSENGER INTERIOR SUN VISORS | | |



Prepared for:
 ROBERT TOLER
 PARMA HEIGHTS CITY OF
 6281 PEARL RD
 PARMA HEIGHTS, OH 44130
 Phone: 440-345-5970

Prepared by:
 Greg Simonic
 VALLEY FREIGHTLINER, INC.
 10901 Brookpark Rd
 Parma, OH 44130
 Phone: 216-267-4800

| Data Code | Description | Weight Front | Weight Rear |
|-----------------------------------|--|--------------|-------------|
| Instruments & Controls | | | |
| 106-002 | ELECTRONIC ACCELERATOR CONTROL | | |
| 732-998 | NO INSTRUMENT PANEL-DRIVER | | |
| 734-022 | FULLY CONFIGURABLE CENTER INSTRUMENT PANELS | | |
| 87L-001 | ENGINE REMOTE INTERFACE WITH PARK BRAKE INTERLOCK | | |
| 870-002 | BRIGHT ARGENT FINISH GAUGE BEZELS | | |
| 486-001 | LOW AIR PRESSURE INDICATOR LIGHT AND AUDIBLE ALARM | | |
| 840-001 | DUAL NEEDLE PRIMARY AND SECONDARY AIR PRESSURE GAUGE | | |
| 198-025 | INTAKE MOUNTED AIR RESTRICTION INDICATOR WITHOUT GRADUATIONS | | |
| 721-003 | 87 DECIBELS TO 112 DECIBELS AUTOMATIC SELF-ADJUSTING BACKUP ALARM | | 3 |
| 149-015 | ELECTRONIC CRUISE CONTROL WITH CONTROLS ON STEERING WHEEL SPOKES | | |
| 156-007 | KEY OPERATED IGNITION SWITCH AND INTEGRAL START POSITION; 4 POSITION OFF/RUN/START/ACCESSORY | | |
| 811-044 | PREMIUM INSTRUMENT CLUSTER WITH 5.0 INCH TFT COLOR DISPLAY | | |
| 81B-003 | DIGITAL PANEL LAMP DIMMER SWITCH IN DRIVER DISPLAY | | |
| 160-038 | HEAVY DUTY ONBOARD DIAGNOSTICS INTERFACE CONNECTOR LOCATED BELOW LH DASH | | |
| 844-001 | 2 INCH ELECTRIC FUEL GAUGE | | |
| 148-072 | ENGINE REMOTE INTERFACE WITH ONE OR MORE SET SPEEDS | | |
| 48H-002 | QUICKFIT POWERTRAIN INTERFACE CONNECTOR LOCATED BETWEEN SEATS WITH BLUNTCUTS | | |
| 163-014 | ENGINE REMOTE INTERFACE CONNECTOR AT POWERTRAIN INTERFACE CONNECTOR | | |
| 856-001 | ELECTRICAL ENGINE COOLANT TEMPERATURE GAUGE | | |
| 852-002 | ELECTRIC ENGINE OIL PRESSURE GAUGE | | |
| 864-022 | DIGITAL TRANSMISSION OIL TEMPERATURE IN DRIVER DISPLAY | | |
| 867-004 | ELECTRONIC OUTSIDE TEMPERATURE SENSOR DISPLAY IN DRIVER MESSAGE CENTER | | |
| 830-017 | ENGINE AND TRIP HOUR METERS INTEGRAL WITHIN DRIVER DISPLAY | | |
| 372-123 | PTO CONTROLS FOR ENHANCED VEHICLE ELECTRIC/ELECTRONIC ARCHITECTURE | | |



Prepared for:
 ROBERT TOLER
 PARMA HEIGHTS CITY OF
 6281 PEARL RD
 PARMA HEIGHTS, OH 44130
 Phone: 440-345-5970

Prepared by:
 Greg Simonic
 VALLEY FREIGHTLINER, INC.
 10901 Brookpark Rd
 Parma, OH 44130
 Phone: 216-267-4800

| Data Code | Description | Weight Front | Weight Rear |
|-----------|--|--------------|-------------|
| 736-998 | NO OBSTACLE DETECTION SYSTEM | | |
| 72J-998 | NO DR ASSIST SYSTEM | | |
| 49B-004 | ELECTRONIC STABILITY CONTROL | | |
| 73B-998 | NO LANE DEPARTURE WARNING SYSTEM | | |
| 72K-998 | NO REVERSE PROXIMITY SENSOR | | |
| 679-998 | NO OVERHEAD INSTRUMENT PANEL | | |
| 746-143 | 7" B-PANEL INTERACTIVE TOUCHSCREEN DISPLAY RADIO W/ USB-C, APPLE CARPLAY, ANDROID AUTO, BLUETOOTH/AM/FM/SXM/WB, WITH MICROPHONE | | |
| 747-001 | DASH MOUNTED RADIO | | |
| 750-002 | (2) RADIO SPEAKERS IN CAB | | |
| 753-008 | AM/FM ANTENNA MOUNTED ON LH SIDE MIRROR | 2 | |
| 748-006 | POWER AND GROUND WIRING PROVISION OVERHEAD | | |
| 749-001 | ROOF/OVERHEAD CONSOLE CB RADIO PROVISION | | |
| N 75W-002 | SHARKFIN MULTI-BAND ANTENNA: AM/FM/WEATHERBAND, WIFI/BLUETOOTH, SDAR/SIRIUSXM, GNSS/GPS | | |
| 78C-003 | INTEROPERABLE SDAR ANTENNA | | |
| 810-027 | ELECTRONIC MPH SPEEDOMETER WITH SECONDARY KPH SCALE, WITHOUT ODOMETER | | |
| 817-001 | STANDARD VEHICLE SPEED SENSOR | | |
| 812-001 | ELECTRONIC 3000 RPM TACHOMETER | | |
| 813-1C8 | DETROIT CONNECT PLATFORM HARDWARE | | |
| 8D1-313 | 3 YEARS DAIMLER CONNECTIVITY BASE PACKAGE ON (FEATURES VARY BY MODEL) POWERED BY DETROIT CONNECT ON CUMMINS ENGINES | | |
| 8DE-998 | NO ASE DATA SVCE EXTENSION | | |
| 6TS-005 | TMC RP1226 ACCESSORY CONNECTOR LOCATED BEHIND PASSENGER SIDE REMOVEABLE DASH PANEL | | |
| 162-002 | IGNITION SWITCH CONTROLLED ENGINE STOP | | |
| 329-129 | FOUR EXTRA HARDWIRED SWITCHES IN DASH, ROUTE TO UNDER CAB, BLUNTCUT | | |
| 4C1-025 | HARDWIRE SWITCH #1, ON/OFF LATCHING, 20 AMPS IGNITION POWER | | |
| 4C2-025 | HARDWIRE SWITCH #2, ON/OFF LATCHING, 20 AMPS IGNITION POWER | | |
| 4C3-016 | HARDWIRE SWITCH #3, ON/OFF LATCHING, 20 AMPS IGNITION POWER | | |
| 4C4-016 | HARDWIRE SWITCH #4, ON/OFF LATCHING, 20 AMPS IGNITION POWER | | |



Prepared for:
 ROBERT TOLER
 PARMA HEIGHTS CITY OF
 6281 PEARL RD
 PARMA HEIGHTS, OH 44130
 Phone: 440-345-5970

Prepared by:
 Greg Simonic
 VALLEY FREIGHTLINER, INC.
 10901 Brookpark Rd
 Parma, OH 44130
 Phone: 216-267-4800

| Data Code | Description | Weight Front | Weight Rear |
|-------------------------------------|--|--------------|-------------|
| 81Y-005 | PRE-TRIP INSPECTION FEATURE FOR EXTERIOR LAMPS ONLY | | |
| 264-030 | (1) OVERHEAD MOUNTED LANYARD CONTROL FOR DRIVER AIR HORN | | |
| 883-998 | NO TRAILER HAND CONTROL BRAKE VALVE | | |
| 842-006 | DIGITAL TURBO AIR PRESSURE IN DRIVER DISPLAY | | |
| 836-015 | DIGITAL VOLTAGE DISPLAY INTEGRAL WITH DRIVER DISPLAY | | |
| 660-025 | SINGLE ELECTRIC WINDSHIELD WIPER MOTOR WITH DELAY WHEN PARK BRAKE SET, TRANSITION TO SLOWEST SPEED | | |
| 304-030 | ROTARY HEADLAMP SWITCH, MARKER LIGHTS/HEADLIGHTS SWITCH WITH PULL OUT FOR OPTIONAL FOG/ROAD LAMPS | | |
| 882-009 | ONE VALVE PARKING BRAKE SYSTEM WITH WARNING INDICATOR | | |
| 299-020 | SELF CANCELING TURN SIGNAL SWITCH WITH DIMMER, HEADLAMP FLASH, WASH/WIPE/INTERMITTENT | | |
| 298-046 | INTEGRAL ELECTRONIC TURN SIGNAL FLASHER WITH 40 AMP (20 AMP PER SIDE) TRAILER LAMP CAPACITY | | |
| 87T-998 | NO WRG/SW-OPTL #2, CHAS, AIR | | |
| Design | | | |
| 065-000 | PAINT: ONE SOLID COLOR | | |
| Color | | | |
| 980-5F6 | CAB COLOR A: L0006EY WHITE ELITE EY | | |
| 986-020 | BLACK, HIGH SOLIDS POLYURETHANE CHASSIS PAINT | | |
| 962-972 | POWDER WHITE (N0006EA) FRONT WHEELS/RIMS (PKWHT21, TKWHT21, W, TW) | | |
| 966-972 | POWDER WHITE (N0006EA) REAR WHEELS/RIMS (PKWHT21, TKWHT21, W, TW) | | |
| 963-003 | STANDARD E COAT/UNDERCOATING | | |
| Extended Front Axle Coverage | | | |
| WA4-035 | AXLE: DETROIT FRONT ONLY: HD MODERATE 5 YEARS/100,000 MILES/161,000 KM EXTENDED AXLE COVERAGE | | |
| Certification / Compliance | | | |
| 996-001 | U.S. FMVSS CERTIFICATION, EXCEPT SALES CABS AND GLIDER KITS | | |

TOTAL VEHICLE SUMMARY



Prepared for:
 ROBERT TOLER
 PARMA HEIGHTS CITY OF
 6281 PEARL RD
 PARMA HEIGHTS, OH 44130
 Phone: 440-345-5970

Prepared by:
 Greg Simonic
 VALLEY FREIGHTLINER, INC.
 10901 Brookpark Rd
 Parma, OH 44130
 Phone: 216-267-4800

Weight Summary

| | Weight Front | Weight Rear | Total Weight |
|---------------------------------|-----------------|-----------------|------------------|
| Factory Weight ⁺ | 8198 lbs | 8068 lbs | 16266 lbs |
| Dealer Installed Options | 0 lbs | 0 lbs | 0 lbs |
| Total Weight⁺ | 8198 lbs | 8068 lbs | 16266 lbs |

Extended Warranty

- WAI-47H CUM 2017 L9: HD1 MD DTY 5 YEARS / 100,000 MILES / 161,000 KM EXTENDED WARRANTY. FEX APPLIES
- WBB-344 TC4: MD MODERATE 5 YEARS/100,000 MILES / 161,000 KM EXTENDED TRUCK COVERAGE. FEX APPLIES
- WAL-262 AXLE: NON-DETROIT TANDEM REAR ONLY: MD MODERATE 5 YEAR/100,000 MILE/161,000 KM EXTENDED COVERAGE

Dealer Installed Options

| | | Weight Front | Weight Rear |
|---------------------------------------|---------------------|-----------------|----------------|
| CNCRD | CONCORD QUOTE 90260 | 0 | 0 |
| Total Dealer Installed Options | | 0 lbs | 0 lbs |

(+) Weights shown are estimates only.
 If weight is critical, contact Customer Application Engineering.

(***) All cost increases for major components (Engines, Transmissions, Axles, Front and Rear Tires) and government mandated requirements, tariffs, and raw material surcharges will be passed through and added to factory invoices.



Prepared for:
 ROBERT TOLER
 PARMA HEIGHTS CITY OF
 6281 PEARL RD
 PARMA HEIGHTS, OH 44130
 Phone: 440-345-5970

Prepared by:
 Greg Simonic
 VALLEY FREIGHTLINER, INC.
 10901 Brookpark Rd
 Parma, OH 44130
 Phone: 216-267-4800

D I M E N S I O N S

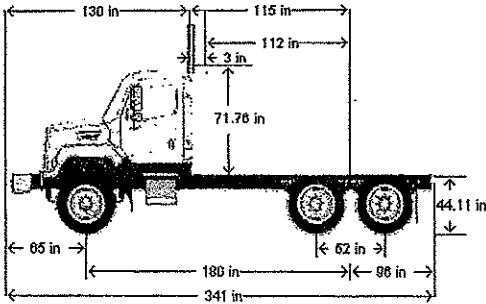

VEHICLE SPECIFICATIONS SUMMARY - DIMENSIONS

| | |
|--------------------------------------|---|
| Wheelbase (545) | 4575MM (180 INCH) WHEELBASE |
| Rear Frame Overhang (552)..... | 2450MM (96 INCH) REAR FRAME OVERHANG |
| Fifth Wheel (578)..... | NO FIFTH WHEEL |
| Mounting Location (577) | NO FIFTH WHEEL LOCATION |
| Maximum Forward Position (in)..... | 0 |
| Maximum Rearward Position (in) | 0 |
| Amount of Slide Travel (in)..... | 0 |
| Slide Increment (in)..... | 0 |
| Desired Slide Position (in)..... | 0.0 |
| Cab Size (829)..... | 108 INCH BBC FLAT ROOF ALUMINUM CONVENTIONAL CAB |
| Sleeper (682)..... | NO SLEEPER BOX/SLEEPER/CAB |
| Exhaust System (016) | RH OUTBOARD UNDER STEP MOUNTED HORIZONTAL AFTERTREATMENT SYSTEM ASSEMBLY WITH RH B-PILLAR MOUNTED VERTICAL TAILPIPE |

TABLE SUMMARY - DIMENSIONS



Prepared for:
 ROBERT TOLER
 PARMA HEIGHTS CITY OF
 6281 PEARL RD
 PARMA HEIGHTS, OH 44130
 Phone: 440-345-5970

Prepared by:
 Greg Simonic
 VALLEY FREIGHTLINER, INC.
 10901 Brookpark Rd
 Parma, OH 44130
 Phone: 216-267-4800

| Dimensions | Values |
|--|--------|
| Bumper to Back of Cab (BBC) | 130.1 |
| Bumper to Centerline of Front Axle (BA) | 64.6 |
| Front Axle to Back of Cab (AC) | 65.6 |
| Min. Cab to Body Clearance (CB) | 3.0 |
| Back of Cab to Centerline of Rear Axle(s) (CA) | 114.6 |
| Effective Back of Cab to Centerline of Rear Axle(s) (Effective CA) | 111.6 |
| Back of Cab Protrusions (Exhaust/Intake) (CP) | 2.0 |
| Back of Cab Protrusions (Side Extenders/Trim Tab) (CP) | 0.0 |
| Back of Cab Protrusions (CNG Tank) | 0.0 |
| Back of Cab Clearance (CL) | 3.0 |
| Back of Cab to End of Frame | 211.1 |
| Cab Height (CH) | 71.8 |
| Wheelbase (WB) | 180.1 |
| Frame Overhang (OH) | 96.5 |
| Overall Frame Length | 341.8 |
| Overall Length (OAL) | 341.2 |
| Rear Axle Spacing | 52.0 |
| Unladen Frame Height at Centerline of Rear Axle | 44.1 |

Performance calculations are estimates only. If performance calculations are critical, please contact Customer Application Engineering.



Prepared for:
 ROBERT TOLER
 PARMA HEIGHTS CITY OF
 6281 PEARL RD
 PARMA HEIGHTS, OH 44130
 Phone: 440-345-5970

Prepared by:
 Greg Simonic
 VALLEY FREIGHTLINER, INC.
 10901 Brookpark Rd
 Parma, OH 44130
 Phone: 216-267-4800

G V W R

VEHICLE SPECIFICATIONS SUMMARY - GVWR

| | |
|---|---|
| Cab Size (829)..... | 108 INCH BBC FLAT ROOF ALUMINUM CONVENTIONAL CAB |
| Expected Front Axle(s) Load (lbs)..... | 18000.0 |
| Expected Pusher Axle(s) Load (lbs)..... | 0.0 |
| Expected Rear Axle(s) Load (lbs)..... | 46000.0 |
| Expected Tag Axle(s) Load (lbs)..... | 0.0 |
| Expected GVW (lbs)..... | 64000 |
| Expected GCW (lbs)..... | 0.0 |
| Front Axle (400)..... | DETROIT DA-F-18-0-5 18,000# FL1 71.0 KPI/3.74 DROP SINGLE FRONT AXLE |
| Front Suspension (620)..... | 20,000# FLAT LEAF FRONT SUSPENSION |
| Front Hubs (418)..... | CONMET PRESET PLUS PREMIUM IRON FRONT HUBS |
| Front Disc Wheels (502)..... | ACCURIDE 29039 22.5X9.00 10-HUB PILOT 5.25 INSET 5-HAND STEEL DISC FRONT WHEELS |
| Front Tires (093)..... | MICHELIN XZU-S2 315/80R22.5 20 PLY RADIAL FRONT TIRES |
| Front Brakes (402)..... | MERITOR 16.5X6 Q+ CAST SPIDER CAM FRONT BRAKES, DOUBLE ANCHOR, FABRICATED SHOES |
| Steering Gear (536)..... | TRW TAS-85 POWER STEERING |
| Rear Axle (420)..... | MERITOR RT-46-160 46,000# R-SERIES TANDEM REAR AXLE |
| Rear Suspension (622)..... | HENDRICKSON HAULMAX EX 46,000# REAR SUSPENSION |
| Rear Hubs (450)..... | CONMET PRESET PLUS PREMIUM IRON REAR HUBS |
| Rear Disc Wheels (505)..... | ACCURIDE 28828 22.5X8.25 10-HUB PILOT 2-HAND HD STEEL DISC REAR WHEELS |
| Rear Tires (094)..... | MICHELIN XDN2 12R22.5 16 PLY RADIAL REAR TIRES |
| Rear Brakes (423)..... | MERITOR 16.5X7 Q+ CAST SPIDER HEAVY DUTY CAM REAR BRAKES, DOUBLE ANCHOR, FABRICATED SHOES |
| Pusher / Tag Axle (443)..... | NO PUSHER OR TAG AXLE |
| Pusher / Tag Suspension (626)..... | NO PUSHER OR TAG SUSPENSION |
| Pusher / Tag Hubs (449)..... | NO PUSHER OR TAG HUBS |
| Dead/Pusher/Tag Disc Wheels (509)..... | NO PUSHER/TAG DISC WHEELS |
| Pusher / Tag Tires (095)..... | NO PUSHER/TAG TIRES |
| Pusher / Tag Brakes (456)..... | NO PUSHER/TAG BRAKES |

TABLE SUMMARY - GVWR



Prepared for:
 ROBERT TOLER
 PARMA HEIGHTS CITY OF
 6281 PEARL RD
 PARMA HEIGHTS, OH 44130
 Phone: 440-345-5970

Prepared by:
 Greg Simonic
 VALLEY FREIGHTLINER, INC.
 10901 Brookpark Rd
 Parma, OH 44130
 Phone: 216-267-4800

| | Front | Rear 1 | Rear 2 |
|--------------------------------------|-------|--------|--------|
| Axle Component Weight Ratings | | | |
| Axles | 18000 | 23000 | 23000 |
| Suspension | 20000 | 23000 | 23000 |
| Hubs | 23000 | 26000 | 26000 |
| Brakes | 20000 | 23000 | 23000 |
| Wheels | 20000 | 32000 | 32000 |
| Tires | 20000 | 27120 | 27120 |
| Power Steering | 18000 | N/A | N/A |
| GAWR (per axle) | 18000 | 23000 | 23000 |
| GAWR (per axle system) | 18000 | | 46000 |
| Expected Load (per axle system) | 18000 | | 46000 |
| GVWR due to Frame | 90000 | | |
| GVWR due to Transmission | 80000 | | |
| Vehicle GVWR Summary | | | |
| Calculated GVWR | 64000 | | |
| Expected GVWR | 64000 | | |
| All weights displayed in pounds | | | |

Performance calculations are estimates only. If performance calculations are critical, please contact Customer Application Engineering.



Prepared for:
 ROBERT TOLER
 PARMA HEIGHTS CITY OF
 6281 PEARL RD
 PARMA HEIGHTS, OH 44130
 Phone: 440-345-5970

Prepared by:
 Greg Simonic
 VALLEY FREIGHTLINER, INC.
 10901 Brookpark Rd
 Parma, OH 44130
 Phone: 216-267-4800

Q U O T A T I O N

108SD PLUS CONVENTIONAL CHASSIS

SET BACK AXLE - TRUCK
 CUM L9 370 HP @ 2100 RPM; 2100 GOV RPM, 1250 LB-
 FT @ 1200 RPM
 ALLISON 3000 RDS AUTOMATIC TRANSMISSION WITH
 PTO PROVISION
 MERITOR RT-46-160 46,000# R-SERIES TANDEM REAR
 AXLE
 HENDRICKSON HAULMAAX EX 46,000# REAR
 SUSPENSION
 DETROIT DA-F-18.0-5 18,000# FL1 71.0 KPI/3.74 DROP
 SINGLE FRONT AXLE
 20,000# FLAT LEAF FRONT SUSPENSION

108 INCH BBC FLAT ROOF ALUMINUM CONVENTIONAL
 CAB
 4575MM (180 INCH) WHEELBASE
 NO FIFTH WHEEL
 7/16X3-9/16X11-1/8 INCH STEEL FRAME
 (11.11MMX282.6MM/0.437X11.13 INCH) 120KSI
 2450MM (96 INCH) REAR FRAME OVERHANG
 1/4 INCH (6.35MM) C-CHANNEL INNER FRAME
 REINFORCEMENT
 TEM TO EVALUATE AND INSTALL FRAME RAIL
 REINFORCEMENT AS NEEDED FOR FRONT
 FRAME MOUNTED EQUIPMENT

| | | PER UNIT | TOTAL |
|----------------------------------|-------------------------|-------------------|-------------------|
| VEHICLE PRICE | TOTAL # OF UNITS (1) | \$ 137,143 | \$ 137,143 |
| EXTENDED WARRANTY | | \$ 3,555 | \$ 3,555 |
| DEALER INSTALLED OPTIONS | | \$ 132,639 | \$ 132,639 |
| CUSTOMER PRICE BEFORE TAX | | \$ 273,337 | \$ 273,337 |
| TAXES AND FEES | | | |
| TAXES AND FEES | | \$ 0 | \$ 0 |
| OTHER CHARGES | | \$ 0 | \$ 0 |
| TRADE-IN | | | |
| TRADE-IN ALLOWANCE | | \$ (0) | \$ (0) |
| BALANCE DUE | (LOCAL CURRENCY) | \$ 273,337 | \$ 273,337 |

The proposed vehicle/vehicles may or may not be available with a variety of safety and collision mitigation options in which the specifications will identify if they are included. If this is a bare chassis order please consult with your bodybuilder to ensure all dimensions, ratings, and necessary chassis components for proper installation are included in this specification. All specifications and pricing are subject to final production, engineering review, availability, and Mfg. surcharges. Invoicing will occur upon delivery to the customer or dropship point and payable upon receipt. Titles will be transferred and delivered upon receipt of payment and signed documents. A signed proposal or purchase order to this proposal thereby agrees to the pricing, specifications, and terms herein unless other arrangements are documented, but does not guarantee production.



Awarded Contract

Contract #032824-DAI

APPROVAL:

Please indicate your acceptance of this quotation by signing below:

Customer: X _____

Date: ___/___/___



RFP 032824 - Class 4-8 Chassis and Cabs with Related Equipment, Accessories, and Services

Vendor Details

Company Name: Daimler Trucks North America
Does your company conduct business under any other name? If yes, please state: Freightliner LLC, Western Star Truck Sales Inc.
Address: 4555 N. Channel Avenue
Portland , Oregon 97217
Contact: Eugene Berg
Email: eugene.berg@daimlertruck.com
Phone: 503-939-3033
HST#: 93-0790608

Submission Details

Created On: Wednesday February 14, 2024 18:28:59
Submitted On: Thursday March 28, 2024 09:56:59
Submitted By: Eugene Berg
Email: eugene.berg@daimlertruck.com
Transaction #: 351f998f-52bc-41d6-9e5b-c374ebf0eb65
Submitter's IP Address: 163.116.129.117
